

ES series ES104

Two-way Loudspeaker System

The **ES104** is a highly weather-resistant, single 4" 2-way full range loudspeaker, the body is made of engineering plastic injection molding, fitted with one 4" mid-woofer and one 0.8" dome tweeter. The system conforms to IP46 international standard. ES104T is equipped with multi-tap transformer based on ES104.

ES104是一个4"两分音系列音箱。箱体设计优先考虑全天候使用环境，采用工程塑胶注塑而成，一只4寸中低音单元和一只20芯球顶高音配置。带T的产品配置多种电压选择功能。产品符合IP46国际标准。

CONFIGURATION

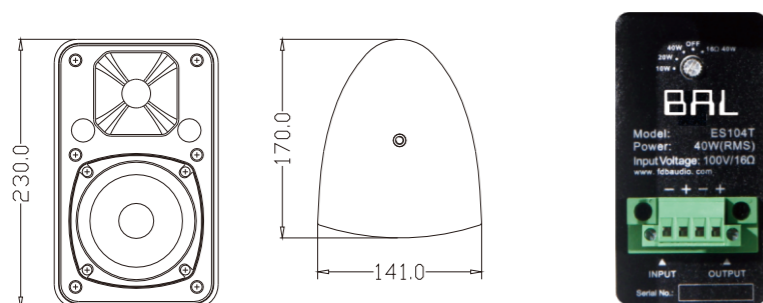

FEATURES

- Highly weather-resistant IP46 rating
- Engineering plastic injection molding
- Two kinds of mounting brackets
- Good used for meeting rooms, shops, water parks, outdoor background music, swimming pools, and a wide variety of other outdoor or indoor background music

产品特点

- 采用工程塑胶注塑而成
- 超长品质保证期：品质与信心的保证

适用范围

- 用于分散扩声
- 会议室
- 主题公园、景区扩声

MODEL	ES104B/ES104W	ES104BT/ES104WT
FREQUENCY RESPONSE(-3dB)	75Hz-20kHz	75Hz-20kHz
FREQUENCY RESPONSE(-10dB)	70Hz-20kHz	70Hz-20kHz
DRIVERS	1×4"(100mm)/1"voice coil LF 1×0.8"(20mm)/dome tweeter	1×4"(100mm)/1"voice coil LF 1×0.8"(20mm)/dome tweeter
INPUT VOLTAGE		100V
RATED POWER	40W RMS,160W peak	10W/20W/40W/OFF/16Ω
SENSITIVITY	88dB 1watt/1 metre	88dB 1watt/1 metre
MAXIMUM SPL	103dB continuous,109 dB peak	103dB continuous,109 dB peak
IMPEDANCE	16 ohms nominal	16 ohms nominal
DISPERSION(-6dB)	120°×90°	120°×90°
CROSSOVER FREQUENCIES	3.5kHz passive	3.5kHz passive
INPUT CONNECTORS	covered barrier strip terminals	covered barrier strip terminals
PACKAGE SIZE	414×190×285mm(1Pair)	414×190×285(1Pair)
NET WEIGHT	2 kg/pc	3 kg/pc
GROSS WEIGHT	6 kg/pair	7 kg/pair

ES series ES106

Two-way Loudspeaker System

The **ES106** is a highly weather-resistant, single 6" 2-way full range loudspeaker, the body is made of engineering plastic injection molding, fitted with one 6" mid-woofer and one 1" HF driver. The system conforms to IP46 international standard. ES106T is equipped with multi-tap transformer based on ES106.

ES106是一个6"两分音系列音箱。箱体设计优先考虑全天候使用环境，采用工程塑胶注塑而成，一只6寸中低音单元和一只25芯高音驱动器。带T的产品配置多种电压选择功能。产品符合IP46国际标准。

CONFIGURATION

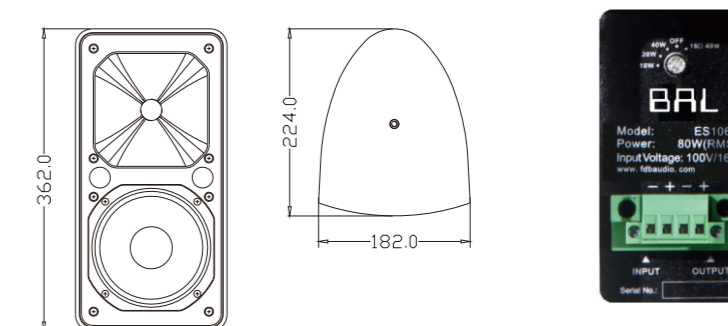

FEATURES

- Highly weather-resistant IP46 rating
- Engineering plastic injection molding
- Two kinds of mounting brackets
- Good used for meeting rooms, shops, water parks, outdoor background music, swimming pools, and a wide variety of other outdoor or indoor background music

产品特点

- 采用工程塑胶注塑而成
- 超长品质保证期：品质与信心的保证

适用范围

- 用会议室多功能厅
- 主题公园、景区扩声

MODEL	ES106B/ES106W	ES106BT/ES106WT
FREQUENCY RESPONSE(-3dB)	60Hz-18kHz	60Hz-18kHz
FREQUENCY RESPONSE(-10dB)	55Hz-20kHz	55Hz-20kHz
DRIVERS	1×6"(150mm)/1.5"voice coil LF 1×1"(25mm)/1"voice coil HF	1×6"(150mm)/1.5"voice coil LF 1×1"(25mm)/1"voice coil HF
INPUT VOLTAGE		100V
RATED POWER	80W RMS,320W peak	20W/40W/80W/OFF/16Ω
SENSITIVITY	89dB 1watt/1 metre	89dB 1watt/1 metre
MAXIMUM SPL	110dB continuous,116 dB peak	110dB continuous,116 dB peak
IMPEDANCE	16 ohms nominal	16 ohms nominal
DISPERSION(-6dB)	90°×60°	90°×60°
CROSSOVER FREQUENCIES	2.4kHz passive	2.4kHz passive
INPUT CONNECTORS	covered barrier strip terminals	covered barrier strip terminals
PACKAGE SIZE	524×242×417mm(1 pair)	524×242×417mm(1 pair)
NET WEIGHT	5 kg/pc	6 kg/pc
GROSS WEIGHT	15 kg/pair	16 kg/pair