

## ES series ES108

### Two-way Loudspeaker System

The **ES108** is a highly weather-resistant, single 8" 2-way full range loudspeaker, the body is made of engineering plastic injection molding, fitted with one 8" mid-woofer and one 1" HF driver. The system conforms to IP46 international standard. ES108T is equipped with multi-tap transformer based on ES108.

ES108是一个8"两分音系列音箱。箱体设计优先考虑全天候使用环境，采用工程塑胶注塑而成，一只8寸中低音单元和一只25芯高音驱动器。带T的产品配置多种电压选择功能。产品符合IP46国际标准。

#### CONFIGURATION

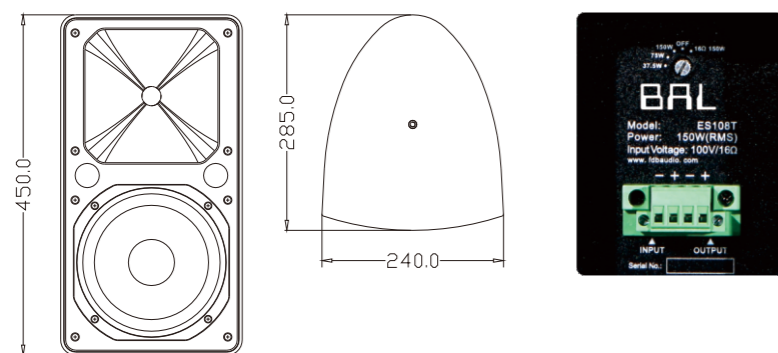

#### FEATURES

- Highly weather-resistant IP46 rating
- Engineering plastic injection molding
- Two kinds of mounting brackets
- Good used for meeting rooms, shops, water parks, outdoor background music, swimming pools, and a wide variety of other outdoor or indoor background music

#### 产品特点

- 采用工程塑胶注塑而成
- 超长品质保证期：品质与信心的保证

#### 适用范围

- 用会议室多功能厅
- 主题公园、景区扩声

## MINI series MINI105

### Two-way Loudspeaker System

The **MINI 105** is a two-way loudspeaker system with one 5" woofer and 1" exit compression driver coupled to a round 140°×140° wide dispersion horn.

MINI 105是一款5"两分音箱。采用一只5"高效率低音单元,一只1"喉口25芯高分子聚脂膜高音驱动器配置140°×140°宽指向性号角,箱体采用多层复合夹板,水性环保喷涂制作。

#### CONFIGURATION

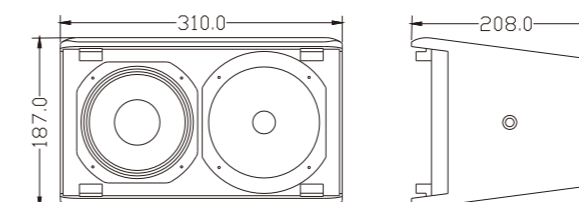

#### FEATURES

- High quality plywood with special environmental protection paint
- Round 140°×140° wide dispersion horn
- Multi-angle rigging bracket
- Used for conference room, small clubs and luxury shops.

#### 产品特点

- 高质量单元配置，多层复合夹板箱体
- 多种吊挂点，操作简易快捷
- 超长品质保证期：品质与信心的保证

#### 适用范围

- 用于语言会议系统、全频扩声
- 多功能厅、高级酒店会所
- 奢侈品店等

MODEL	ES108B/ES108W	ES108BT/ES108WT
FREQUENCY RESPONSE(-3dB)	60Hz-18kHz	60Hz-18kHz
FREQUENCY RESPONSE(-10dB)	55Hz-20kHz	55Hz-20kHz
DRIVERS	1×8"(200mm)/2"voice coil LF 1×1"(25mm)/1"voice coil HF	1×8"(200mm)/2"voice coil LF 1×1"(25mm)/1"voice coil HF
INPUT VOLTAGE		100V
RATED POWER	150W RMS,600W peak	37.5W/75W/150W/OFF/16Ω
SENSITIVITY	94dB 1watt/1 metre	94dB 1watt/1 metre
MAXIMUM SPL	116dB continuous,122 dB peak	116dB continuous,122 dB peak
IMPEDANCE	16 ohms nominal	16 ohms nominal
DISPERSION(-6dB)	90°×50°	90°×50°
CROSSOVER FREQUENCIES	2.3kHz passive	2.3kHz passive
INPUT CONNECTORS	covered barrier strip terminals	covered barrier strip terminals
PACKAGE SIZE	370×310×525mm	370×310×525mm
NET WEIGHT	9 kg/pc	10 kg/pc
GROSS WEIGHT	11 kg/pair	12 kg/pair



FREQUENCY RESPONSE(75Hz)	-18KHz
FREQUENCY RESPONSE(-10dB)	z-20kHz
DRIVERS	1x5"(130mm)/1.5"voice coil LF 1×1"(25mm)/1"voice coil HF
RATED POWER	80W RMS,320W peak
SENSITIVITY	89dB 1watt/1 metre
MAXIMUM SPL	108dB continuous,114 dB peak
IMPEDANCE	16 ohms nominal
DISPERSION(-6dB)	140°×140°
CROSSOVER FREQUENCIES	2.3kHz passive
INPUT CONNECTORS	Terminal Clamp
PACKAGE SIZE	583mm×266mm×405mm(carton/pair)
NET WEIGHT	6 kg/pc
GROSS WEIGHT	14 kg/pair